

AUSTRALIAN LIFTING CENTRE PTY LTD

G100 CHAIN & FITTINGS

Breaking The Lifting Barrier

AUSTLIFT



BONCON
INDUSTRIAL
LIFTING & EQUIPMENT

 **AUSTLIFT®**

Austlift™ G100 products are manufactured & tested to the requirements of Australian Standard 2321 'Short Link Chain for Lifting Purpose' & AS3776 'Lifting Components for Grade T Chain Slings' in extremely high quality.

All G100 products are made from alloy steel, the chemical composition conforms to EN1677:2000 specification. They are quenched & tempered, uniformly marked with equivalent chain size, grade, batch number, manufacturer's ID & Product 'Type Code' for positive identification.

Our factory has official approval by Lloyd's for quality management to ISO9002: 1194 in year 2000, approval by TUV (Rheinland) for quality assurance to DIN/EN 1677-1 in year 2001, & by main national certification authorities.

We regard your safety as our priority. Destructive tests are applied to every batch on a random sampling. Test Certificates are available upon request.

When you choose Austlift™ you choose quality.

1300 100 120

WWW.AUSTLIFT.COM.AU

PDF compression, OCR, web optimization using a watermarked evaluation copy of CVISION PDFCompressor

G100

Contents

<i>Alloy Chain</i>	10
<i>Welded Master Link (With Flat)</i>	10
<i>Master Link Multi (Type Md)</i>	11
<i>Connecting Link</i>	11
<i>Clevis Grab Hook</i>	12
<i>Eye Shortening Grab Hook</i>	12
<i>Self Locking Hook, Clevis Type (LC)</i>	13
<i>Self Locking Hook, Eye Type (LE)</i>	13
<i>Self Locking Hook, Swivel Type (LS)</i>	14
<i>Clevis Sling Hook (With Latch)</i>	14
<i>Working Load Limits</i>	15
<i>Eye Sling Hook (With Latch)</i>	15
<i>Spare Parts</i>	16
<i>Chain Sling Tag & Connecting Ring</i>	17

AUSTLIFT

G100 - Alloy Chain



Austlift G100 Chain is made in Germany, generally used for Chain Slings with 25% higher lifting capacity than G80. Manufactured from hardened and tempered alloy steels and has a high resistance to impact and wear to meet critical requirements of AS 2321 "Short Link Chain for lifting purposes". Chain links are formed from German Wafos link machine technology to produce its high quality of lightweight strength, durability and safety of lifting chain applications.

- Sizes available from 8mm to 22mm.
- Marked with chain grade and traceability mark.
- Made from G100 alloy steel with safety factor of 4 to 1.
- Conforms to AS 2321 but with 25% higher work load limit.
- Batch tested, Test Certificates available upon request.

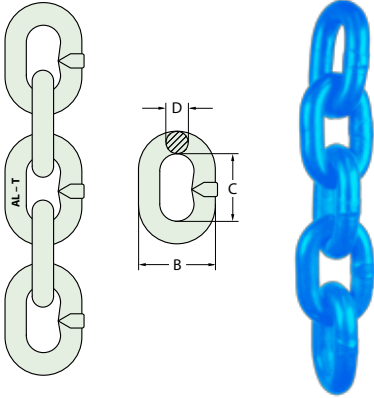

CODE	SIZE mm	WLL tonne	Wt. kg per m	DIMENSIONS		
				B mm	C mm	D mm
171008	8	2.5	1.4	28	24	8
171010	10	4	2.2	35	30	10
171013	13	6.7	3.8	46	39	13
171016	16	10	5.7	56	48	16
171020	20	16	9	70	60	20
171022	22	19	10.9	78	66	22

Welded Master Link (with flat)



Austlift SD Type G100 Head-Rings are designed to cater for single leg and double leg Chain Slings or Wire Rope Sling applications.

- Marked with single and double chain sizes, designation, grade with manufacture quality mark and Austlift branded
- Manufactured from G100 alloy steel with safety factor of 4 to 1
- Manufactured and tested in accordance to AS 3776 but with 25% higher work load limit.
- Test Certificates available upon request.

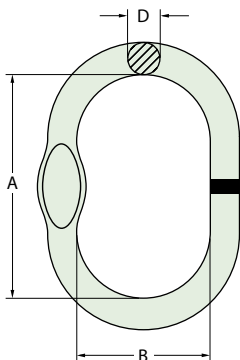

CODE	CHAIN SIZE		WLL tonne	Wt. kg	DIMENSIONS		
	1 leg mm	2 leg mm			A mm	B mm	D mm
170008	8	6	2.5	0.4	120	70	14
170010	10	8	4.0	0.7	140	80	17
170013	13	10	7.5	1.5	160	95	22
170016	16	13	10	2.2	190	110	25
170020	20	16	17	5.1	240	140	34
170022	22	20	25	7.2	250	150	38

Austlift MD Type G100 Multi Head Rings are designed with a large ring and two intermediate links to cater for two, three and four leg Chain Sling or Wire Rope Sling applications.

- Marked with chain size, designation, grade with manufacture quality mark and Austlift branded
- Made from G100 alloy steel with safety factor of 4 to 1
- Test Certificates available upon request.
- Manufactured and tested in accordance to AS 3776 but with 25% higher work load limit.

CODE	SIZE	WLL	Wt.	DIMENSIONS					
				B	B1	C	C2	D	D1
	mm	tonne	kg	mm	mm	mm	mm	mm	mm
170106	6	3.5	1.8	90	19	150	120	19	14
170108	8	5	3.0	95	22	160	140	22	17
170110	10	8	6.5	120	30	200	160	30	22
170113	13	14	15	150	40	250	200	40	30
170116	16	21	23	200	50	300	200	50	32

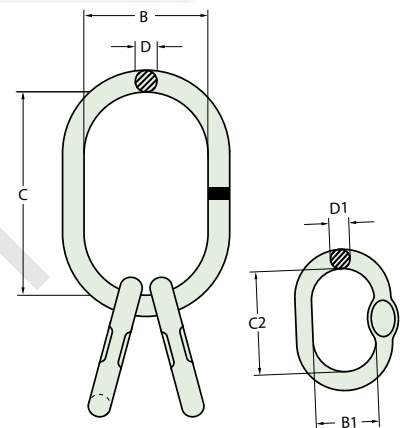

Connecting Link

Austlift CL Type G100 Connecting Links are commonly used to connect head rings, chain, Hooks and other lifting components for Chain Slings. Sizes available from 6mm to 22mm

- Marked with chain size, grade and Austlift branded.
- Made from G100 alloy steel with a safety factor of 4 to 1.
- Manufactured and tested in accordance to AS 3776 but with 25% higher work load limit.
- Batch tested, Test Certificates available upon request.



CODE	CHAIN SIZE	WLL	Wt.	DIMENSIONS			
				B	K	D	L
	mm	tonne	kg	mm	mm	mm	mm
170206	6	1.4	0.1	14	44.5	7.6	60
170208	8	2.5	0.22	18.5	61.5	10	84.5
170210	10	4	0.45	23	72	12.6	97.2
170213	13	6.7	1.15	27.5	89	16.8	127
170216	16	10	1.75	33.5	103	21	145
170220	20	15.6	2.7	42	116	24.5	175
170222	22	19	4.02	48	135	27	193

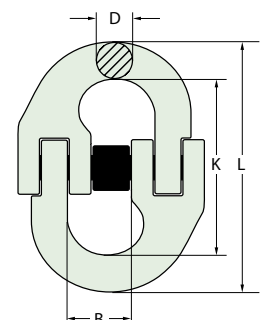

Clevis Grab Hook



Austlift GC Type G100 Clevis Grab Hooks provide the flexibility to shorten chain leg on a sling may also be used for back-hooking. Grab Hooks come with supporting lugs to allow no reduction of the working load limit. The clevis is designed for ease of connection of chain.

- Marked with chain size, designation, grade with manufacture quality mark and Austlift branded.
- Made from G100 alloy steel with safety factor of 4 to 1
- Manufactured and tested in accordance to AS 3776 but with 25% higher work load limit.
- Test Certificates available upon request.

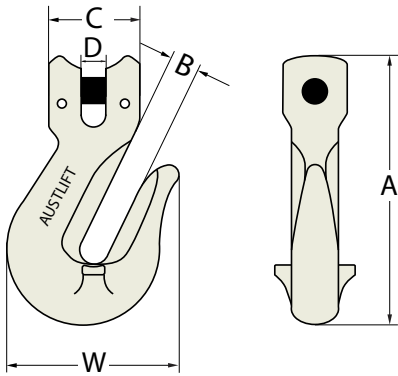

CODE	CHAIN SIZE	WLL	Wt.	DIMENSIONS				
				A	B	C	D	W
	mm	tonne	kg	mm	mm	mm	mm	mm
170306	6	1.4	0.22	75	8	32	7.5	43.5
170308	8	2.5	0.34	91.5	10.8	36	9.5	53
170310	10	4	0.82	126	13.5	46	12	72
170313	13	6.7	1.75	136.5	16.5	59	15	96
170316	16	10	2.88	183.5	19.2	70	17.5	112.5
170320	20	16	4.84	224	24	85	24	143
170322	22	19	8.3	262	27	100	27	160.5

Eye Shortening Grab Hook



Austlift GE Type G100 Eye Grab Hook provide the flexibility to shorten chain leg on a sling may also be used for back-hooking. Grab Hooks come with supporting lugs to allow no reduction of the working load limit. The eye is designed for ease of connection of coup-link.

- Marked with chain size, designation, grade with manufacture quality mark and Austlift branded
- Made from G100 alloy steel with safety factor of 4 to 1.
- Manufactured and tested in accordance to AS 3776 but with 25% higher work load limit.
- Test Certificates available upon request.

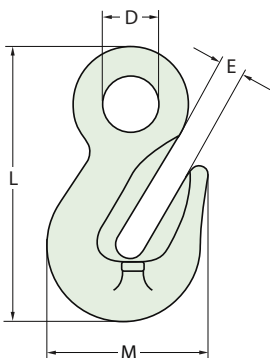

CODE	CHAIN SIZE	WLL	Wt.	DIMENSIONS			
				D	E	M	L
	mm	tonne	kg	mm	mm	mm	mm
170406	6	1.4	0.2	14.5	8	43.5	70
170408	8	2.5	0.28	18	10.8	53	91
170410	10	4	0.72	22.5	13.5	42	126
170413	13	6.7	1.6	28	16.5	96	162
170416	16	10	2.45	36	19.2	112.5	182
170420	20	16	4.72	43.5	24	143	225
170422	22	19	8.2	48.5	27	160.5	259

Self Locking Hook, Clevis Type (LC)

Austlift LC Type G100 Clevis Self-Locking Hook allows the hook to be easily closed with one hand, it will close itself when the load is engaged. The Hook will not open until the trigger at the back is pressed. Clevis style allows easy connection to the Chain.

- Marked with chain size, designation, grade with manufacture quality mark and Austlift branded.
- Manufactured from G100 alloy steel with a safety factor of 4 to 1.
- Manufactured and tested in accordance to AS 3776 but with 25% higher work load limit.
- Test Certificates available upon request.
- Spare Trigger Kits and Load Pins are available.



CODE	CHAIN SIZE		Wt.	DIMENSIONS					
	mm	tonne		A	E	R	H	L	M
170506	6	1.4	0.5	7.5	28	96	20	131	70
170508	8	2.5	0.9	9.5	35.5	123	26	166	90
170510	10	4	1.6	12	45	144	30	196.5	109
170513	13	6.7	2.9	15	53.5	182	40.5	251	138.5
170516	16	10	5.8	17.5	62	217	50.5	303	170.5
170520	20	16	8.6	25	76.5	235	62	337.5	192.5
170522	22	19	12.1	25.5	80	276.5	66	391	205

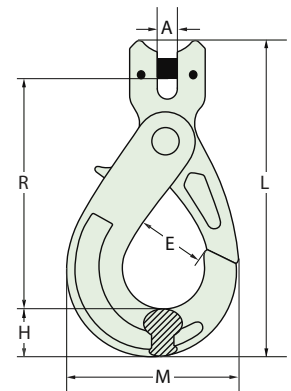

Self Locking Hook, Eye Type (LE)

Austlift LE Type G100 Eye Self-Locking Hook allows the hook to be easily closed with one hand, it will close itself when the load is engaged. The Hook will not open until the trigger at the back is pressed. Eye style allows easy connection to Coup Links, Shackles and Wire.

- Marked with chain size, designation, grade with manufacture quality mark and Austlift branded.
- Manufactured from G100 alloy steel with a safety factor of 4 to 1.
- Manufactured and tested in accordance to AS 3776 but with 25% higher work load limit.
- Test Certificates available upon request.



CODE	CHAIN SIZE		Wt.	DIMENSIONS					
	mm	tonne		D	E	R	H	L	M
170606	6	1.4	0.5	21	28	110	20	141	70
170608	8	2.5	0.9	27	35.5	137	26	175	90
170610	10	4	1.5	34.5	45	169	30	212.5	108
170613	13	6.7	2.7	40	53.5	209	40.5	270	138.5
170616	16	10	5.7	50	62	254	50.5	331	170.5
170620	20	16	7.9	60	76.5	277	62	369	192.5
170622	22	19	11.2	70	80	319.5	66	417	205

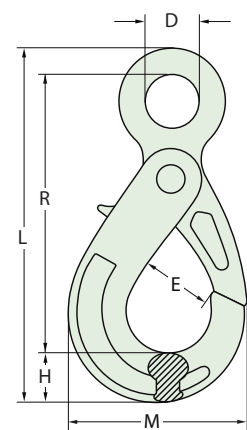

Self Locking Hook, Swivel Type (LS)

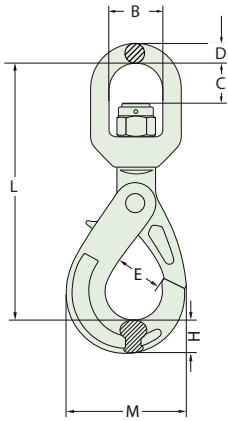

Austlift LS Type G100 Swivel Self-locking Hook have a plain bearing swivel to allow the hook to swivel thus reducing the twist of a sling.

- Marked with chain size, designation, grade with manufacture quality mark and Austlift branded
- Manufactured from G100 alloy steel with a safety factor of 4 to 1.
- Manufactured and tested in accordance to AS 3776 but with 25% higher work load limit.
- Test Certificates available upon request.
- Spare Trigger Kits are available.

CODE	CHAIN SIZE	WLL	Wt.	DIMENSIONS						
				B	C	D	E	H	M	L
	mm	tonne	kg	mm	mm	mm	mm	mm	mm	mm
170706	6	1.4	0.6	32.5	23	11.5	28	20	70	180
170708	8	2.5	1.1	36	28	13	35.5	26	90	229
170710	10	4	2	42	35	15.5	45	30	109	269
170713	13	6.7	4	50	40	17	53.5	40.5	138.5	330
170716	16	10	6.8	61	56	21.5	62	50.5	170.5	413
170720	20	16	12.5	72	62	26	76.5	62	192.5	463
170722	22	19	17.1	97	94	33	80	66	205	572

Clevis Sling Hook (with Latch)



Austlift SC Type G100 Clevis Sling Hook are a general purpose hook suitable for most slinging applications and comes with a cast latch for added safety.

Clevis allows easy connection to chain.

- Marked with chain size, designation, grade with manufacture quality mark and Austlift branded
- Manufactured from G100 alloy steel with a safety factor of 4 to 1.
- Manufactured and tested in accordance to AS 3776 but with 25% higher work load limit.
- Test Certificates available upon request.

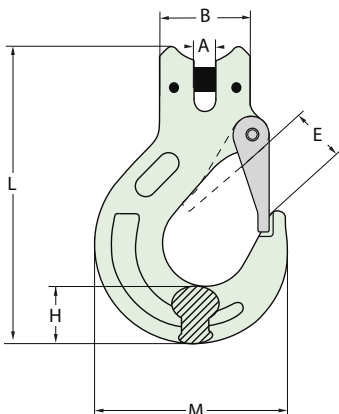

CODE	CHAIN SIZE	WLL	Wt.	DIMENSIONS					
				A	B	E	H	M	L
	mm	tonne	kg	mm	mm	mm	mm	mm	mm
170806	6	1.4	0.33	7.5	32	18.5	21	68.5	109
170808	8	2.5	0.7	9.5	37	25	27.5	88	134
170810	10	4	1.3	12	48	28	33.5	105.5	161.5
170813	13	6.7	2.3	15	59	38	42	134	203
170816	16	10	3.6	17.5	70	44	50	160.5	248
170820	20	16	7.3	25	85	52	56	190.5	297
170822	22	19	12.1	27	100	66	62	214.5	326

Austlift SE Type G100 Eye Sling Hooks are a general purpose hook suitable for most slinging applications and come with a cast latch for added safety. Eye allows easy connection to coup links and can be attached to lifting apparatus.

- Marked with chain size, designation, grade with manufacture quality mark and Austlift branded.
- Manufactured from G100 alloy steel with a safety factor of 4 to 1.
- Manufactured and tested in accordance to AS 3776 but with 25% higher work load limit.
- Test Certificates available upon request.



CODE	CHAIN SIZE	WLL	Wt.	DIMENSIONS				
				B	D	E	H	L
	mm	tonne	kg	mm	mm	mm	mm	mm
170906	6	1.4	0.32	20.5	10	18.5	21	111
170908	8	2.5	0.6	25	11	25	27.5	137.5
170910	10	4	1.2	34	16	28	33	171.5
170913	13	6.7	2.2	43	19	38	43.5	219
170916	16	10	3.5	50	24.5	44	50	260
170920	20	16	7.15	55	27	52	56	298

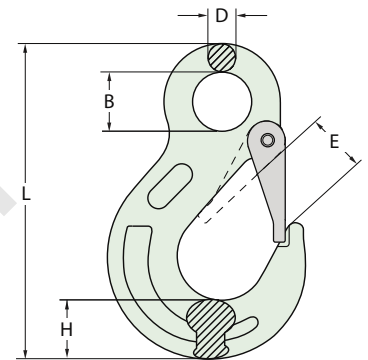

G100 Chain Sling

Austlift can make G100 Chain Slings to your requirement. Please call 1300 100 120 for a quote.



WORKING LOAD LIMITS (TONNES)

GRADE 100 (T) Chain Slings

DIA	DIRECT LOAD	ADJUSTABLE SLING	CHOKE	ENDLESS SLING									
				DIRECT LOAD			REEVED SLING			BASKET HITCH			REEVED SLING
Load Factor				60°	90°	120°	60°	90°	120°	60°	90°	120°	
	1	1	0.8	1.73	1.4	1	1.3	1.06	0.75	1.3	1.06	0.75	1.5
6	1.4	1.4	1.12	2.4	1.95	1.4	1.82	1.48	1.05	7.8	1.48	1.05	2.1
8	2.5	2.5	2.0	4.3	3.5	2.5	3.25	2.65	1.87	3.25	2.65	1.85	3.75
10	4.0	4.0	3.2	6.9	5.6	4.0	5.2	4.24	3.0	5.2	4.24	3.0	6
13	6.7	6.7	5.2	11.2	9.2	6.7	8.7	7.1	5.0	8.71	7.1	5.0	10.05
16	10.0	10	8.0	17.3	14.1	10	13	10.6	7.5	13	10.6	7.5	15
20	16.0	16.0	12.8	23.6	22.4	16.0	20.8	21.2	12	20.8	21.2	12	24
22	19.0	19.0	15.2	32.8	26.6	19.0	24.7	20.14	14.25	19.0	20.14	14.25	28.5

SPARE PARTS



Safety Latch for Sling Hook

CODE	SIZE	SUIT FOR PRODUCTS		
		mm	Eye	Clevis
030006SP	6		SE-6-10	SC-6-10
030008SP	8		SE-8-10	SC-8-10
030010SP	10		SE-10-10	SC-10-10
030013SP	13		SE-13-10	SC-13-10
030016SP	16		SE-16-10	SC-16-10
030020SP	20		SE-20-10	SC-20-10
030022SP	22		SE-22-10	SC-22-10



Safety Trigger Kit for Self Locking Hook

CODE	SIZE	SUIT FOR PRODUCTS			
		mm	Eye	Clevis	Swivel
030106	6		LE-6-10	LC-6-10	LS-6-10
030108	8		LE-8-10	LC-8-10	LS-8-10
030110	10		LE-10-10	LC-10-10	LS-10-10
030113	13		LE-13-10	LC-13-10	LS-13-10
030116	16		LE-16-10	LC-16-10	LS-61-10
030120	20		LE-20-10	LC-20-10	LS-20-10
030122	22		LE-22-10	LC-22-10	LS-22-10

CODE	SIZE	SUIT FOR PRODUCTS		
	mm	Clevis Sling Hook	Clevis Self Lock Hook	Clevis Grab Hook
030606SP	6	SC-6-10	LC-6-10	GC-6-10
030608SP	8	SC-8-10	LC-8-10	GC-8-10
030610SP	10	SC-10-10	LC-10-10	GC-10-10
030613SP	13	SC-13-10	LC-13-10	GC-13-10
030616SP	16	SC-16-10	LC-16-10	GC-16-10
030620SP	20	SC-20-10	LC-20-10	GC-20-10
030622SP	22	SC-22-10	LC-22-10	GC-22-10



Pin for Clevis Hook

CODE	SIZE	SUIT FOR PRODUCTS
	mm	
030706SP	6	CL-6-10
030708SP	8	CL-8-10
030710SP	10	CL-10-10
030713SP	13	CL-13-10
030716SP	16	CL-16-10
030720SP	20	CL-20-10
030722SP	22	CL-22-10



Pin and Stud for Chain connector

Chain Sling Tag & Connecting Ring

Austlift G100 Safe Work Load Tags are essential to identify a Chain Sling's lifting capacity together with other relevant information.

- Single and Multi lifting available.
- Sizes from 8mm to 22mm tags available.
- Manufactured in G304 Stainless Steel material.

SIZE	CODE (Single)	CODE (Multi)
8	090108	090208
10	090110	090210
13	090113	090213
16	090116	090216
20	090120	090220
22	090122	090222



AUSTLIFT

SYDNEY

43 Frank Street Wetherill Park, NSW 2164
T. 02 9757 2277 F. 02 9757 2922

MELBOURNE

47 Technology Drive, Sunshine West VIC 3020
T. 03 9314 5525 F. 03 9314 5526

PERTH

Unit 5, 2-4 Mallaig Way Canning Vale WA 6155
T. 08 9256 3440 F. 08 9256 4408

BRISBANE

7 Durbell St Acacia Ridge, QLD 4110
T. 07 3272 0777 F. 07 3272 0788

www.austlift.com.au